

DRG. No. W28GC003/3  
 DRG. REF.

CUSTOMER  
 ORDER No.  
 PART No.  
 OUR ORDER No.  
 FRAME SIZE  
 KW. RPM.  
 Hz PHASE  
 VOLTS POLES  
 BRGS. DE. NDE.  
 MOTOR NETT WT. Kg.  
 SPECIAL REMARKS

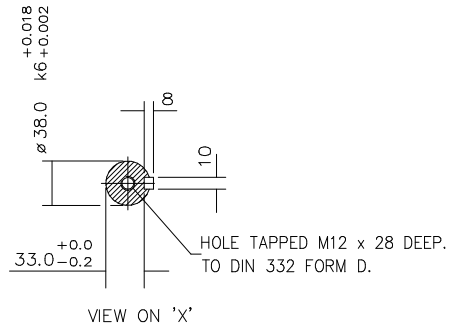
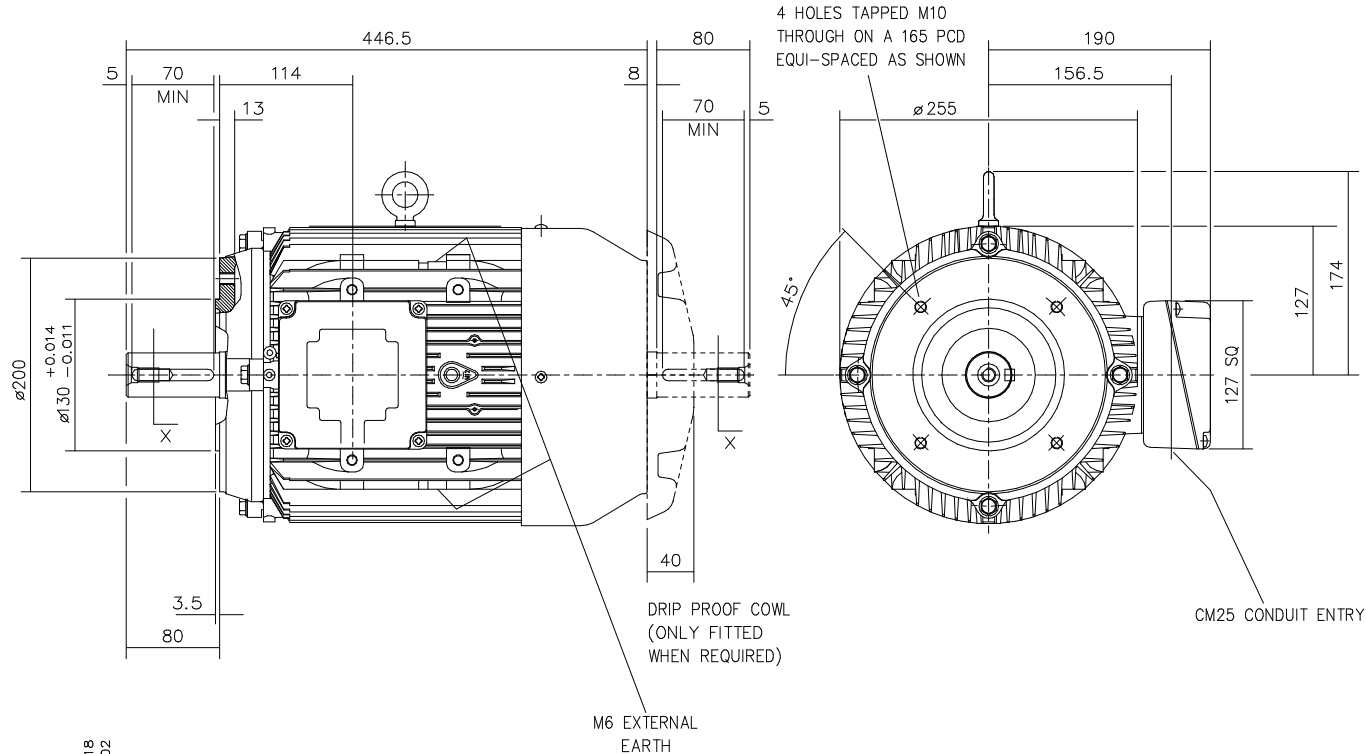

CARE SHOULD BE TAKEN TO ENSURE THAT THE SCREWS OR STUDS DO NOT EXTEND INSIDE MOTOR BEYOND THE DEPTH OF THE TAPPED FIXING HOLE.  
 TERMINAL BOX POSITION : - CAN BE ARRANGED AT EITHER 9, 12 OR 3 O'CLOCK  
 STANDARD TERMINAL BOX POSITION IS 3 O'CLOCK AS SHOWN.  
 CONDUIT ENTRIES:- TERMINAL BOX CAN BE ROTATED AT 90° INTERVALS  
 (CONDUIT ENTRY POSITION SHOWN FOR ILLUSTRATION ONLY).

ALL DIMENSIONS IN MILLIMETRES.



**BROOK CROMPTON**

Huddersfield, HD1 3LJ  
 ENGLAND

SHEET TITLE  
 SIZE OUTLINE DIMENSION DRAWING W ALUMINIUM TOTALLY ENCLOSED FAN COOLED  
 A3 132S/M FRAME 'C' FACE NO FEET MOUNTED MOTOR

	NAME	DATE
DRAWN	VLS	06-10-98
CHECKED	DRM	06-10-98
SCALE	1 : 4	

DRG. No.	W28GC003/3		
DRG. REF.			
REVISION:	DH	DATE	04/08/03